



VW Chassis & Production Numbers

Knowing your Air Cooled Volkswagen's chassis and production numbers can impress your friends. It can also save you time and headaches when tackling a big project or restoration. Mid America Motorworks reviews the basics of important numbers on your VW, including where to find them, what abbreviations mean and how to confirm you choose the correct parts for your projects.

ABBREVIATIONS

OEM	Original Equipment Manufacturer
OE	Original Equipment
Reman.....	Remanufactured
Carb.....	Carbureted
Fuel Inj.....	Fuel Injected
Left or L	Driver Side of Car (left side)
Right or R	Passenger Side of Car (right side)
L/R.....	Left and/or Right
Frt	Front
RR	Rear
Qtr.....	Quarter
P/Up.....	Pickup (Single and/or Crew Cab)
M/T	Manual Transmission
A/T	Automatic Transmission
IRS.....	Independent Rear Suspension
STD	Standard
SB.....	Super Beetle
Conv	Convertible
O.D	Outside Diameter
I.D.....	Inside Diameter
HP.....	Horsepower
Cc.....	Cubic Centimeter
m.....	Meter





- mm..... Millimeter
- oz..... Ounce
- “L, “W, or “H..... Inches Long, Width, Height
- pc, pcs Piece, Pieces
- pr Pair
- ea..... Each
- Ch..... Chassis
- #..... Number
- w/ or w/out With or Without
- NLA..... No longer Available
- T1 or Type 1 Bug Sedan, Convertible & Ghias
- T2 or Type 2 Bus, Pick-up, Crew Cab
- T3 or Type 3 Squareback, Fastback or Notchback

F. A. Q.
(FREQUENTLY ASKED QUESTIONS)

Is your car a Super Beetle?

Super Beetles were first produced in 1971. All Bug Convertibles from 1971-1979 are Super Beetles. If your car’s spare tire lies flat, and/or the car has louvered slots below the front bumper, your car is a Super Beetle. Please note that 71-72 Super Beetles have flat windshields just like Standards. Therefore, a flat windshield does not necessarily mean your car is a Standard Bug.

How to tell if a part fits Convertible, Sedan or Both.

Parts fitting sedans only will specify “Sedan” or “Sed”. Parts fitting Convertible only will specify “Convertible” or “Conv.” Parts fitting both Sedan and Convertible will not specify anything.

IT’S IMPORTANT TO KNOW YOUR CHASSIS NUMBER!

Volkswagen made changes during some model years. Knowing your chassis numbers will help you in ordering the right replacement part. This section is designed to aid you in finding your chassis number.





CHASSIS NUMBER LOCATIONS

Type 1 and Type 3:

1. Stamped on the transmission tunnel under the back seat.

Type 2 vehicles: the Chassis Number can be found in one or more of the following locations:

1. On the vertical surface to the right of the engine (early models).
2. On the Vehicle Identification Number (VIN) plate located on the right side of the overhead fresh air duct in the cab of the Bus.
3. On the panel behind the drivers seat.
4. On the right hand engine cover plate.
5. On the left hand engine cover plate (late models).
6. On the VIN plate near the windshield in front of the drivers position.

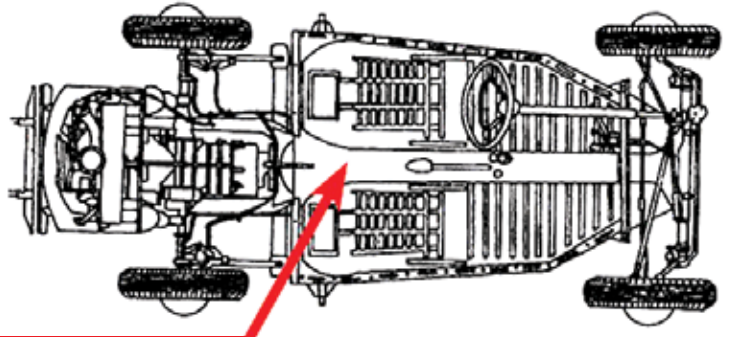

The chassis number will also be the same as the "VIN" number on your title or registration.

MID YEAR CHANGES

Parts that are affected by mid year changes are designated by Chassis numbers. You'll need to check the Chassis number (under rear seat) or VIN number (on your title) to assure you order the correct part for your specific car. When a part fits several different models, we have combined the first three digits of each model's Chassis number. For instance, 1973 was a year in which Super Beetle Convertibles, Super Sedans, and Standard Sedans were produced. The beginning Chassis number for 1973 representing all three models would appear as follows. 153/133/113 2000 001.

