



**Application:** 1985-1996 Corvette

**Part Includes**

- 1 - Air Foil
- ? - Fasteners
- 1 - Allen Wrench

# Throttle Body Air Foil



**Tools Needed**



Search: **Engine Components**  
[www.mamotorworks.com](http://www.mamotorworks.com)

**STEP 1.**

Detach the rubber bellows only at the throttle body end.

**STEP 2.**

Remove the "Tuned Port Injection" aluminum plate (item A) on top of the throttle body.

**STEP 3.**

Carefully remove gasket (item B) for reuse.

**STEP 4.**

Attach the air foil with supplied hardware. We suggest using Loctite Threadlocking agent (available at any parts store) on the screw. The insert nut is placed in through the top of the throttle body. (See diagram. NOTE: 1992+ Corvettes may require slight filing of insert nut edges for proper fit into the throttle body.)

**STEP 5.**

Replace the "TUNED PORT INJECTION" aluminum plate.

**STEP 6.**

Attach the rubber bellows.

The Throttle Body Air Foil is passive and should not affect emissions. **DO NOT, UNDER ANY CIRCUMSTANCES**, alter texture, shape or configuration of this air foil.

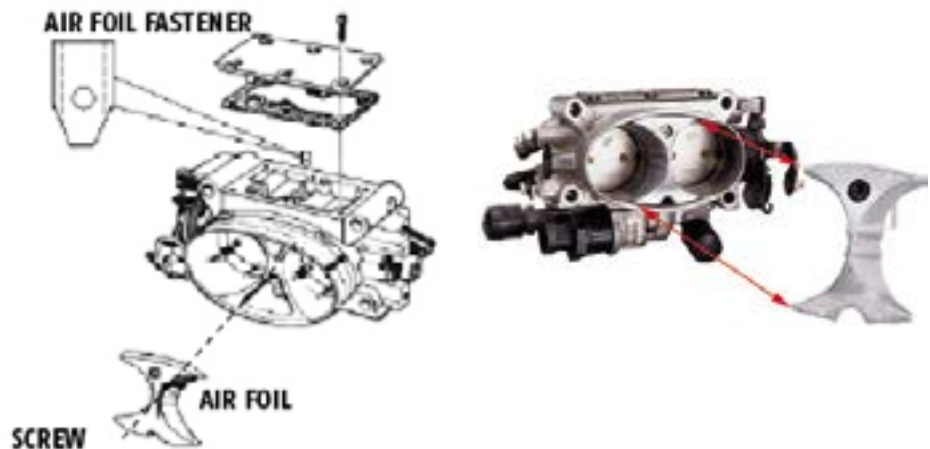

- Mamotorworks
- @CorvettePassion
- MidAmericaMotorworks
- CorvettePassion

2900 North Third Street, Effingham, IL 62401  
 800.500.1500 • Worldwide: 217.540.4200 • FAX: 217.540.4800  
[www.mamotorworks.com](http://www.mamotorworks.com) • [generalmail@mamotorworks.com](mailto:generalmail@mamotorworks.com)  
 ©Mid America Motorworks, Inc. All rights reserved.