



Application: 1984-1987

Part Includes
1 - Component

Headlight Motor Gear



Tools Needed



Search: **Lighting, Headlights**
www.mamotorworks.com

IMPORTANT: Installation by a competent mechanic is recommended. Mid America Motorworks cannot be held responsible for improper installation.

STEP 1.

Open headlight as far as possible and unplug motor at the module connector near the bumper.

STEP 2.

Remove the headlight bezel and the screws that hold the headlight/motor assembly to the under side of the hood.

STEP 3.

The entire assembly, including the motor, can now be removed from the car. Remove the nut that secures the motor shaft to the pivot unit. Remove the Phillips head screws that hold the motor housing halves together. Hold motor with flat side up and separate the top half.

STEP 4.

Lay motor half on work surface. Push shaft upward to gain access to "T" pin. Drive "T" pin out with a hammer and punch.

STEP 5.

Lift gear from motor half, noting position of washer on bottom side of gear.

Side View of Motor Half - with Small Gear

STEP 6.

Install gear on shaft. Drive "T" pin back in position.

STEP 7.

Reassemble motor halves and reinstall in car.

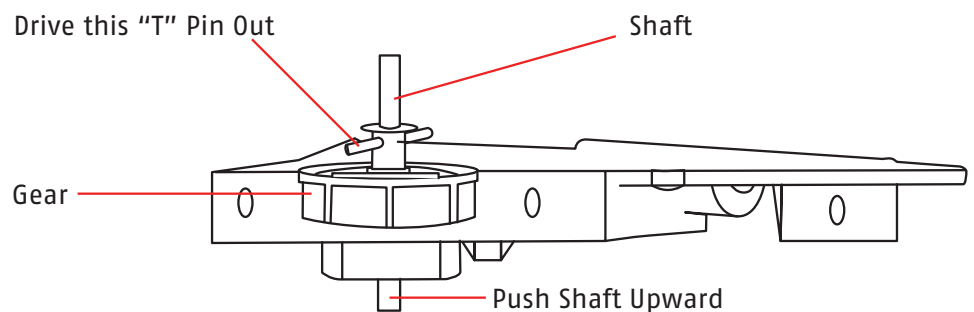

Mamotorworks



@CorvettePassion



MidAmericaMotorworks



CorvettePassion

2900 North Third Street, Effingham, IL 62401
800.500.1500 • Worldwide: 217.540.4200 • FAX: 217.540.4800
www.mamotorworks.com • generalmail@mamotorworks.com
©Mid America Motorworks, Inc. All rights reserved.