



**Application:** Corvette 1963-1977

**Part Includes**

1 - Composite Spring

# TRW Composite Spring



### Tools Needed



Search: *Pedals, Accelerator*  
[www.mamotorworks.com](http://www.mamotorworks.com)

### IMPORTANT INSTRUCTIONS

Proper positioning of the mounting kit in the center of the spring is very important. See the figure on the back of this page for the method to check the position of the center mount.

If necessary slide the center mount into proper position using hand pressure only. Do not cut or remove the assembly seal tape.

Prior to reading the attached instruction sheet, make sure all the components in this package are correct. Cross the part number on the end of the shipping carton with the same number on the following chart and then check for the correct Spring, Installation Kit and Instruction Sheet.

<u>Part No.</u>	<u>Spring Rate</u>	<u>Installation Kit</u>
602-820	315 rate	634-121
602-826	340 rate	634-121
602-832	355 rate	634-121
602-822	315 rate	634-122
602-828	340 rate	634-122
602-834	355 rate	634-122
602-830	340 rate	634-123
602-836	355 rate	634-149

### IMPORTANT!

Proper positioning of the mounting kit in the center of the spring is very important. If necessary, slide the center mount into proper position using hand pressure only. Do not cut or remove the assembly seal tape.

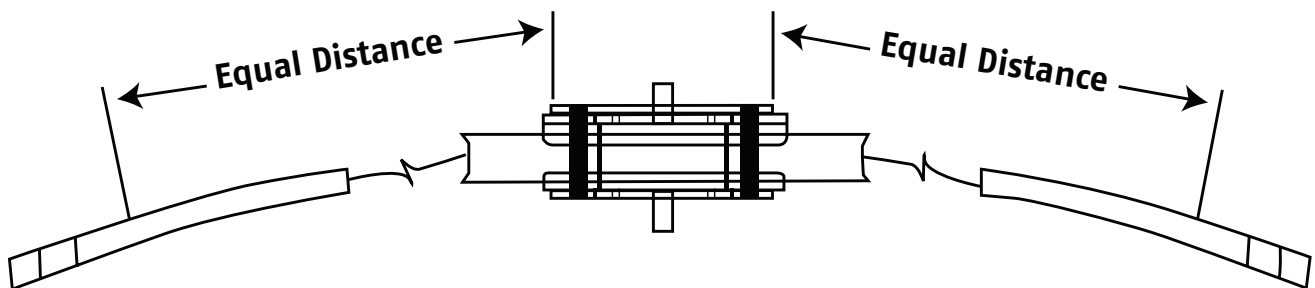

Mamotorworks



@CorvettePassion



MidAmericaMotorworks



CorvettePassion

**2900 North Third Street, Effingham, IL 62401**  
**800.500.1500 • Worldwide: 217.540.4200 • FAX: 217.540.4800**  
**[www.mamotorworks.com](http://www.mamotorworks.com) • [generalmail@mamotorworks.com](mailto:generalmail@mamotorworks.com)**

©Mid America Motorworks, Inc. All rights reserved.



## Description (cont.)

Thank you for purchasing TRW's Composite Corvette Spring. Before proceeding, please read and understand all of the following instructions.

**CAUTION:** Improper installation may result in suspension failure. To ensure proper installation use all of the parts supplied.

**Important Notice to owners of 1963 through 1977 Corvettes.** Due to replacement of failed differential covers, some 1963 through 1977 Corvettes may be equipped with 1978 and 1979 style differential covers. At present, the 1978 end 1979 cover (GM Part #464909) is the only type available from GM.

If your 1963 through 1977 Corvette is so equipped, then the following part numbers must be used in place of those in the catalog:

602-820	Use 600-107	LS1001	Use LS1007
602-826	Use 600-109	LS1003	Use LS1009
602-832	Use 600-111	LS1005	Use LS1011

The type of differential cover may be easily identified by the size of the four spring bolts used:

1963 through 1977 Cover: Bolt Size = 9/16  
Wrench Size = 13/16

1978 through 1979 Cover: Bolt Size = 7/16  
Wrench Size = 5/8

## SHOCK ABSORBERS

Due to the TRW Composite Spring being an advanced single-leaf design that replaces a multi-leaf steel spring, it is able to more rapidly respond to road irregularities. This fast response, providing excellent ride and handling, means that high quality shock absorbers in good condition are more important than with the steel spring currently used on your Corvette. Check the condition of the shock absorbers when installing the composite spring.

Remember, the key to the best in ride and handling for your Corvette is TRW's Composite Spring working together with premium shock absorbers.

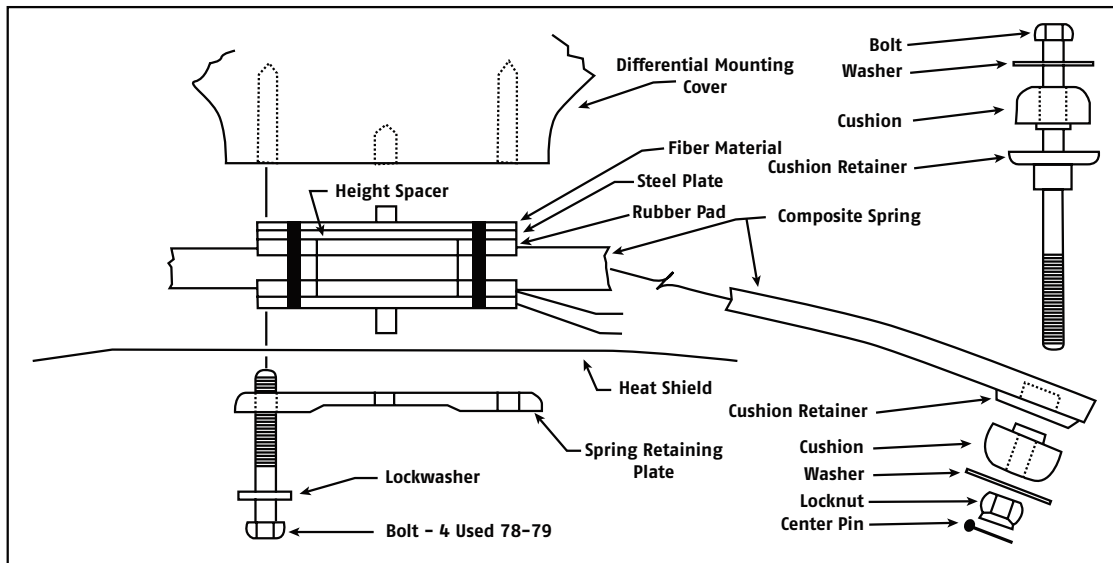



## Description (cont.)

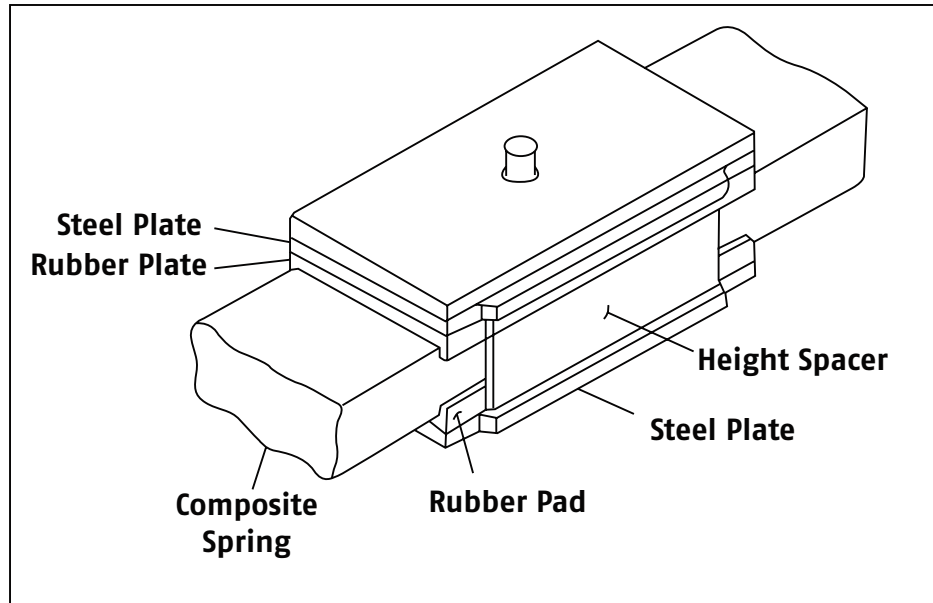

### PART A – REMOVAL OF THE EXISTING SPRING

#### STEP 1.

**CAUTION:** CHOCK THE FRONT WHEELS. Removal of the rear tires is not necessary but makes the job easier. Raise the rear of vehicle and carefully position jack stands at the end of rails just in front of the rear wheels.

#### STEP 2.

Remove the cotter pin from the link bolt (see Figure 1). Carefully loosen the castle nut approximately one (1) turn. If frozen, soak with penetrant until free.

#### STEP 3.

Clamp vise grips on the spring as shown in Figure 2.

#### STEP 4.

Using a floor jack, carefully lift the spring just enough at the vise grip point as shown in Figure 2 to relieve pressure from the castle nut.

**CAUTION:** REMEMBER THAT IN THE DEPRESSED STATE, THE SPRING SUPPORTS THE REAR OF THE VEHICLE. DO NOT LIFT THE SPRING TO WHERE THE VEHICLE LIFTS OFF THE JACK STAND AS THIS WILL CAUSE A DANGEROUS WORKING CONDITION.

Continue by removing the castle nut, washer, and cushion from the link bolt and slowly release the jack. Remove the link bolt, washer, cushion, and cushion retainer from the hub carrier.

#### STEP 5.

Repeat Steps 2, 3, and 4 for the other end of the spring.

#### STEP 6.

At this time loosen or remove the rear of the exhaust system to allow removal of the spring. For most cars, disconnection of the rear hangers will allow the exhaust system to drop enough to provide room to remove the spring. Some late model Corvettes are equipped with an aluminum heat shield covering the center of the spring and differential. Remove and discard this shield.



## Description (cont.)

### STEP 7.

Refer to Figure 1. Remove the four (4) center spring bolts. When using a breaker bar on stubborn bolts, take care that the car does not shift on the jack stands.

### STEP 8.

Remove the spring retaining plate and spring. **CAUTION:** STEEL SPRING WEIGHT IS APPROXIMATELY 40 POUNDS. Check the threads in the differential cover for damage. Installation is easier and the tightening procedure is improved if the threads are clean.

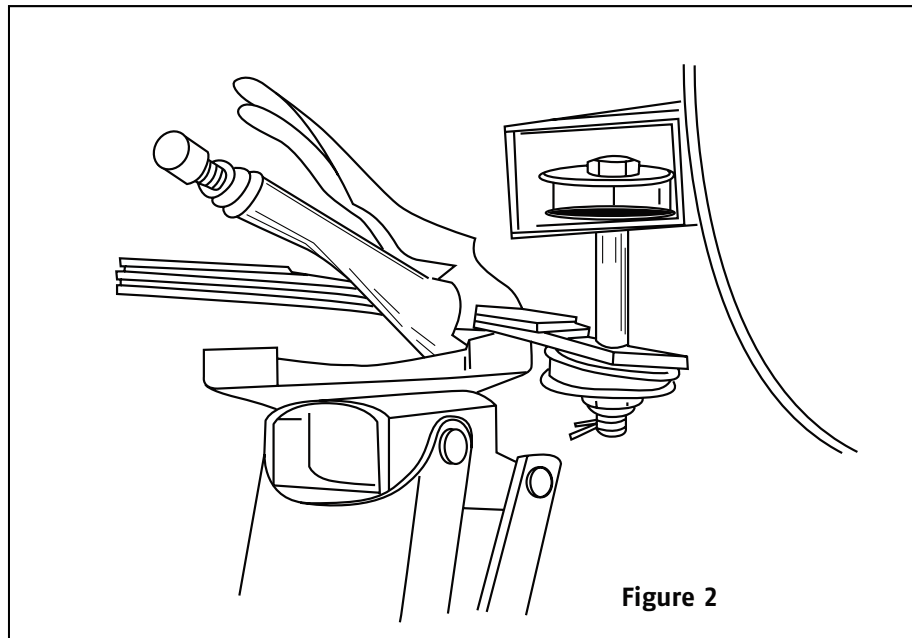

Figure 2

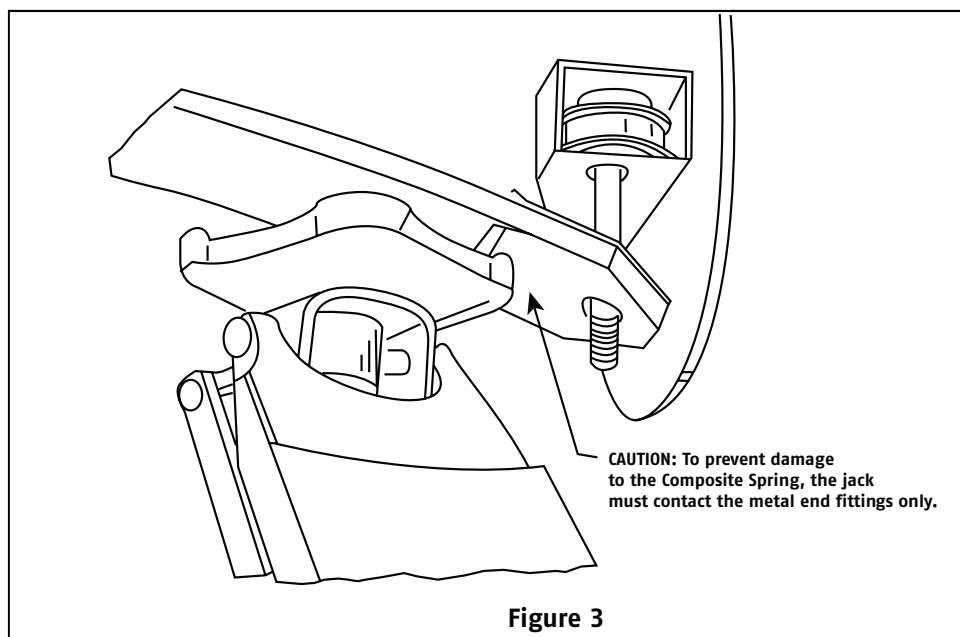

Figure 3



## Description (cont.)

### PART B – INSTALLATION OF YOUR TRW COMPOSITE SPRING.

#### STEP 1.

Remove the spring assembly from the box and check the position of the rubber pad, steel plates, height spacers and fiber insulator. Check that the two tangs on each edge of the two spacers are started into the holes in the two steel plates. THEY MUST BE AS SHOWN IN FIGURE 1. Do not remove the tape holding the plates, spacers, pads, and insulator to the spring.

**IMPORTANT:** INSTALLING THE SPRING ASSEMBLY OTHER THAN AS SHOWN COULD DAMAGE THE SPRING.

#### STEP 2.

Locate the composite spring to the differential cover being sure that the pilot in the center of the spring sets into the hole in the differential cover.

Insert the new spring bolts (provided) through the lockwashers, spring retaining plate, and heat shield (see Figure 1) and tighten finger tight.

**NOTE:** The label on the heat shield indicates proper heat shield positioning.

**NOTE:** Installation of the heat shield is required even when your Corvette is equipped with side pipes.

#### STEP 3.

Tighten the spring bolts, using a torque wrench, evenly to the torque listed below. Do not overtighten. Use of air guns is not recommended. If the front spring bolts stop turning before the spring is tight against the differential cover, remove the bolt and check to see if it is bottoming out in the tapped hole. If necessary, shim the bolt with additional washers under the bolt head.

Spring Bolt Torque:

Kits 602-820, 602-826, 602-832

1. Tighten evenly to 15 foot pounds.
2. Tighten evenly to 30 foot pounds.
3. Finally, tighten evenly to 50 foot pounds.

#### STEP 4.

Insert new link bolts, cushions, cushion retainers, and washers into each hub carrier as shown in Figure 1.

#### STEP 5.

Carefully position the floor jack as shown in Figure 3.

**NOTE:** THAT THE JACK MUST ONLY CONTACT THE COMPOSITE SPRING ON THE METAL END FITTING. APPLYING PRESSURE DIRECTLY TO THE COMPOSITE MATERIAL WILL DAMAGE THE SPRING.

#### STEP 6.

Jack the spring up so that a cushion, washer, and locknut may be installed on the link bolt. Run the locknut onto the link bolt until it just clears the cotter pin hole and install the cotter pin. Repeat for the other end of the spring.

#### STEP 7.

Reattach the exhaust system. Check that the spring clears the exhaust pipes and muffler clamps by a least 1/4" for the entire length of the spring.

#### STEP 8.

Remove the jack stands and lower the car to the ground.

#### STEP 9.

Recheck the spring bolt torque. Check that the heat shield clears the composite spring by at least 1/4".



## **Description** (cont.)

### **STEP 10.**

If your Corvette is equipped with wider than stock tires and/or rims, check that there is adequate clearance between them and the ends of the composite spring.

### **STEP 11.**

Check to be sure that all installation instructions have been followed. Installation of your TRW Composite spring is now complete.

**NOTE:** The link bolts in the kit are made with extra thread length so that adjustments can be made to ride height. Further tightening of the lock nuts on the link bolts will raise the rear of the car. Keep in mind that as the new cushions compress the rear will settle approximately 3/8". Be sure to adjust link bolts equally when adjusting ride height. Adjusting ride height should only be done after driving the car for a short period of time to settle the suspension.