



Application: 1968-1973 Bus - Westfalia Campers

Part Includes

1 - Seal Kit

Camper Pop-Top Seal Kit - OEM



Tools Needed



STEP 1.

Clean slot on extrusion, Figure #1, with alcohol or other rubber cleaner. Insure that all residue is removed from the rubber.

STEP 2.

Apply a film of 3M adhesive in the slot that you just cleaned.

STEP 3.

Apply a 1/2 inch wide strip of adhesive on the edge (Figure #2) of the pop top shell where the rubber in Figure #1 will be placed. Make sure to coat both the top and bottom of this edge.

STEP 4.

Starting at either side of the corner edge of the pop top roof mount the rubber seal by pushing the groove with the glue onto the roof. Make sure not to stretch the seal as you are installing. Leave approximately 1/2 inch on both ends so you can trim the seal to fit with the roof in the closed position.

STEP 5.

Cut approximately 1" of the "U" channel off the long piece of camper roof seal (Figure #3). You can tuck this rubber bulb under the extrusion you just installed to insure a good seal. Starting at the front corner of the roof push the seal in place. When you reach the end trim the "U" channel back as above and finish the installation.

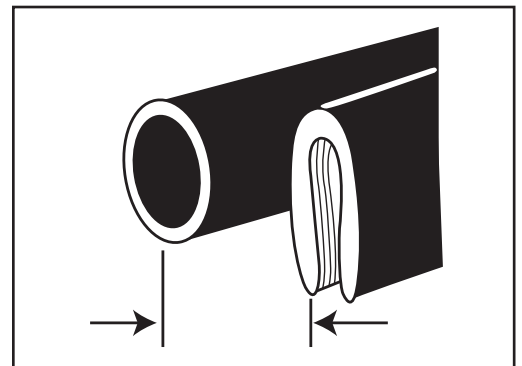
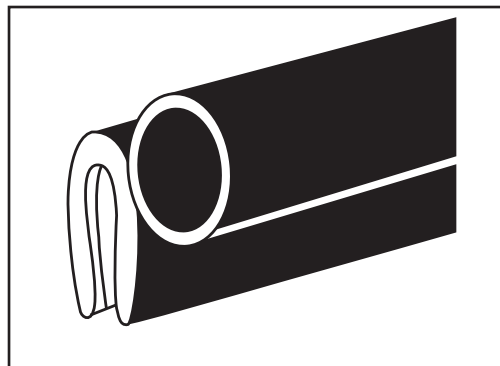
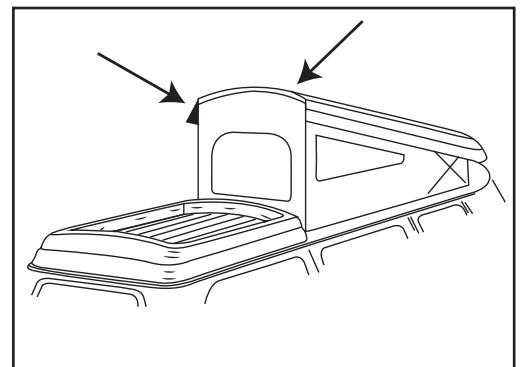
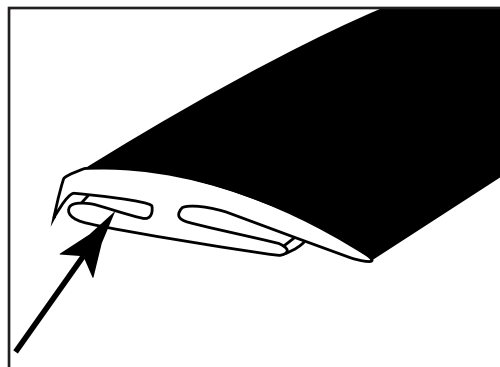

aircooledvws



@acvwpassion



MAMotorworksACVWPassion

2900 North Third Street, Effingham, IL 62401

800.500.1500 • Worldwide: 217.540.4200 • FAX: 217.540.4800

www.mamotorworks.com • generalmail@mamotorworks.com

©Mid America Motorworks, Inc. All rights reserved.