

Chevrolet Corvette Radiator Grille

Kit Contents

Description	Quantity
Grille Mesh (LH)	1
Grille Mesh (RH)	1
Brackets	3
Bolts	4
Washers	4
Installation Instructions	1

Tools Required

- Ratchet Torque Wrench
- Socket (7mm)

Vehicle Preparation

1. Wash and thoroughly dry vehicle.
2. For best results, vehicle should be free of damage (dents, scuffs, creases, fractures, etc.)

Installation

1. Remove 3 screws from the lower grille. Reserve screws. See Figure 1A.

FIGURE 1A

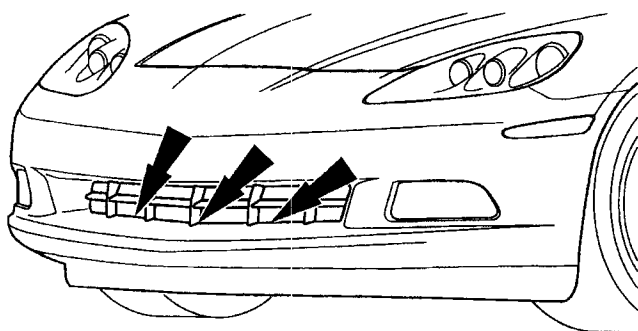

2. Using screws reserved from step 1, install 3 brackets. See Figure 1B.

FIGURE 1B

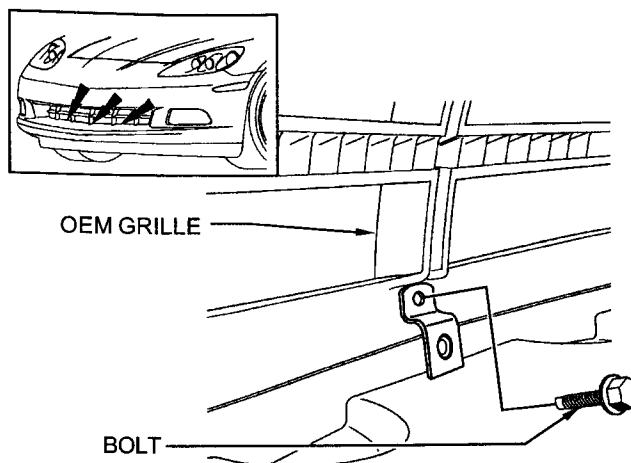

3. Position right hand grille mesh assembly behind the lower grille. Slide to the right, until the edge of the grille mesh is lined up with the center of the middle grille bar. See Figure 1C.

FIGURE 1C

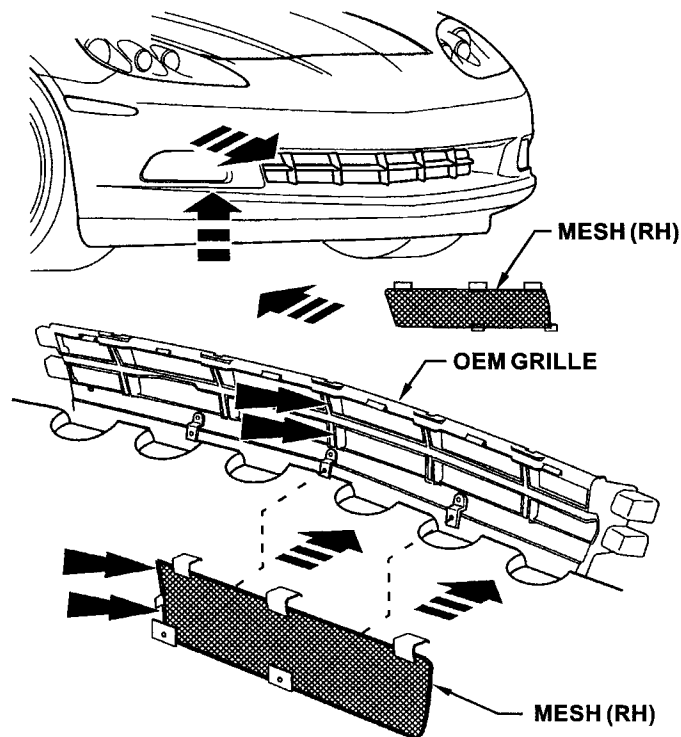

Radiator Grille

REV 07DE05

PART NO.

19132722

SHEET

1

OF **6**

ALL INFORMATION WITHIN ABOVE BORDER TO BE PRINTED EXACTLY AS SHOWN ON 8.5x11 WHITE 18 POUND NON-BOND RECYCLABLE PAPER. PRINT ON BOTH SIDES, EXCLUDING TEMPLATES. TO BE UNITIZED IN ACCORDANCE WITH GMSPO SPECIFICATIONS.

DATE	REVISION	AUTH	DR
21OC05	Initial Release - Mike Rierson		
22NO05	Revised - Mike Rierson		
07DE05	Revised - Mike Rierson		

INSTALLATION INSTRUCTIONS
Radiator Grille

PART NO. **19132722** SHEET **1** OF **6**

4. Ensure that the 3 upper tabs hook over the upper edge of the grille. See Figure 1D.

FIGURE 1D

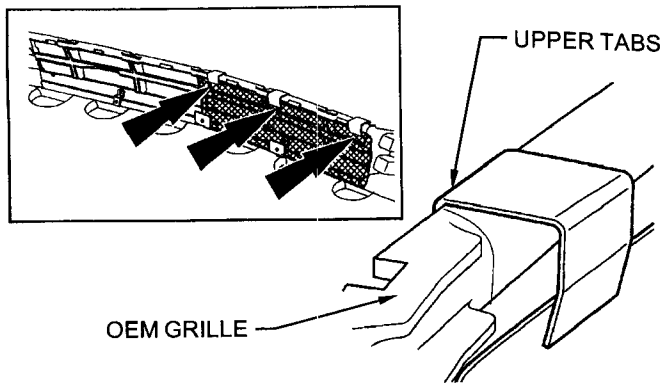

5. Position left hand grille mesh assembly behind the lower grille. Slide to the left, until the edge of the grille mesh is lined up with the center of the middle grille bar, and the edge of the right hand grille mesh. The holes on the two mounting tabs must line up with each other. See Figure 1E. Ensure that the 3 upper tabs hook over the edge of the grille. See Figure 1D.

FIGURE 1E

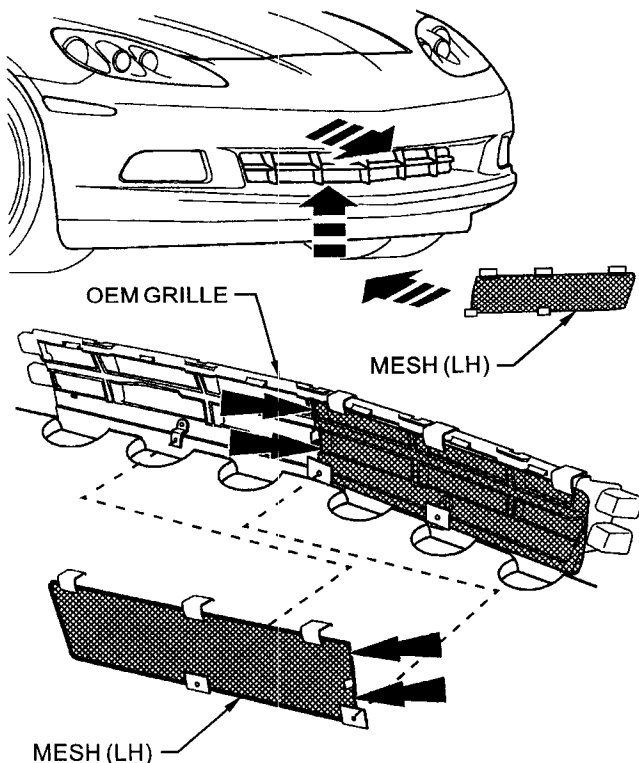

6. Fasten 3 bolts (M4) and washers through the grille mesh tabs into the brackets. Do not fully tighten. See Figure 1F.

FIGURE 1F

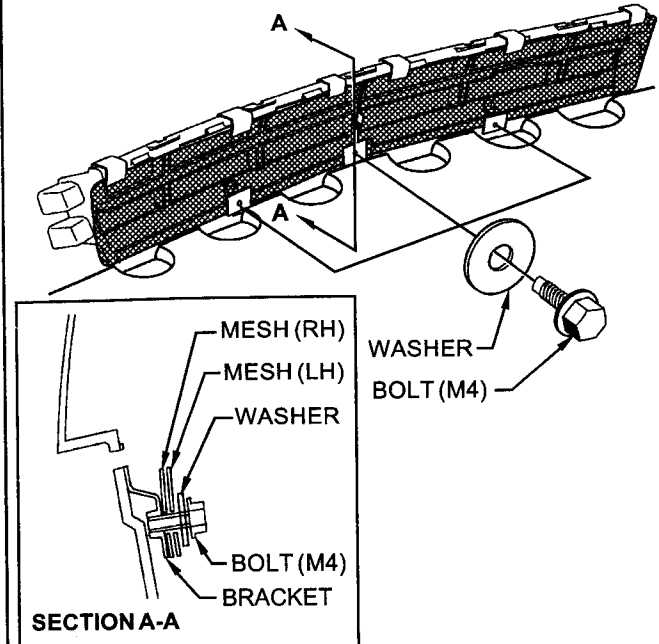

7. Fasten 2 tabs together using bolt (M4) and washer provided. See Figure 1G.
8. Tighten all fasteners to 4.0 N.m

FIGURE 1G

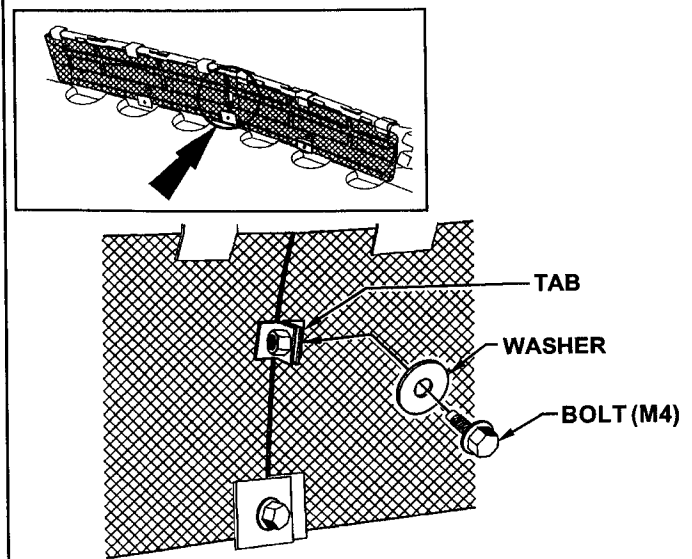

Radiator Grille

REV 07DE05

PART NO.

19132722

SHEET

2 OF **6**

ALL INFORMATION WITHIN ABOVE BORDER TO BE PRINTED EXACTLY AS SHOWN ON 8.5x11 WHITE 16 POUND NON-BOND RECYCLABLE PAPER. PRINT ON BOTH SIDES, EXCLUDING TEMPLATES. TO BE INITIALIZED IN ACCORDANCE WITH GMSPO SPECIFI-

DATE	REVISION	AUTH	DR

INSTALLATION INSTRUCTIONS
Radiator Grille

PART NO.

19132722

SHEET

2 OF **6**