



Suggested Installation Instructions for:
609-645, 1985-1989 Heat Shield, EGR Pipe
609-647, 1985-1991 Heat Shield, EGR Pipe

The 1986-89 pipe has an EGR switch on the top end of the pipe. Remove this switch to install the new heat shield. The 1990-91 does not use the EGR switch. For installation on 1990-91, reverse the new heat shield so that the hole is at the bottom of the pipe.

Installing the New Heat Shield:

1. Remove the positive battery cable.
2. Remove all of the old heat shield.
3. Wrap the new heat shield around the pipe with the two edges pointed towards the rear of the engine.
4. Press the velcro mates together, sliding the shield down while working your way upwards ending at the top of the heat shield at the sensor hole.
5. Align the shield's sensor hole and reinstall the EGR switch, if removed.
6. Reconnect the battery cable.

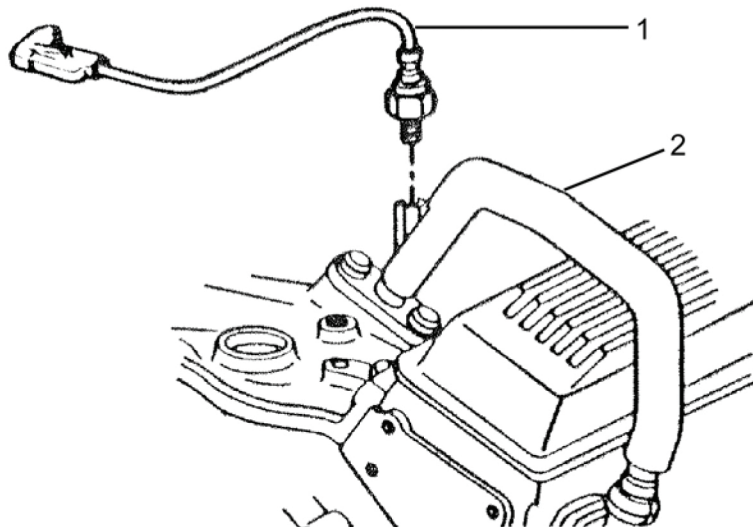

1-EGR Temperature Diagnostic Switch
2-EGR Pipe Shield