

MID AMERICA



MOTORWORKS™

Pursue your passion here®

Suggested Installation Instructions for:

609-126, 609-128, 609-130

Chevrolet Corvette C4

Dual Rear Exit W/ Twin Pro-Series 3.5" Tips

1992-95 LT1 (MAM PN 609-126, CORSA PN: 14116)

1990-95 ZR1 (LT5), (MAM PN 609-128, CORSA PN: 14117)

1996 LT1/LT4 (MAM PN 609-130, CORSA PN: 14118)

Count on Mid America Motorworks for all your Corvette Parts and Corvette Accessories

Please take time to read and understand these installation instructions.

MAM and CORSA recommend that installation of this system be performed by a qualified service center or professional muffler installer who has the necessary equipment, tools, and experiences personnel. However, if you decide to perform this install, the use of a hoist and an additional person will be required.

CAUTION: Never work on a hot exhaust system. Allow time for the vehicle to cool. Always wear eye protection when working under a vehicle.

Please confirm that all parts are present before beginning the factory exhaust system removal and CORSA exhaust system installation.

Recommended Tools:

- Safety Glasses
- 15mm deep socket
- 7/8" wrench (96 models only)
- 13mm wrench or socket
- 9" extension- for 15mm socket
- 9/16" socket
- 1/2" socket
- No-mar hammer
- WD-40
- Floor jack
- 4 jack stands
- Sandpaper
- Torque wrench

Bill of Materials:

- (1) Driver side head pipe (A)
- (1) Passenger side head pipe (B)
- (1) Center muffler (C)
- (1) Driver side Under-axle pipe (D)
- (1) Passenger side Under-axle pipe (E)
- (1) Driver side rear muffler (F)
- (1) Passenger side rear muffler (G)
- (4) 5/16"- 18 x 5/8" bolt
- (4) 5/16"- 18 nut
- (6) 2 1/2" TORCA band clamps (Torque to 45 ft.-lb.)
- (1) 2 3/4" Easy Seal clamp (Torque to 50-70 ft.-lb.)
- Anti-Seize lubricant

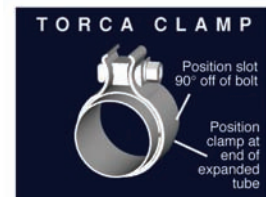

PLEASE NOTE:

On convertible applications, it is necessary to unbolt the factory X-Brace in order to remove the original exhaust. Upon installation of our kit, be sure to reinstall this X-Brace.

All clamps should be tightened using a properly calibrated Torque Wrench. Using an air impact gun will damage the clamp and reduce its ability to effectively seal the joint. It may also cause the joint to separate thereby causing damage to your exhaust system and your vehicle.

CORSA Cat-Back Exhaust System Installation

1. With your Corvette parked on a level surface, jack it up and support it with four jack stands. Give yourself enough room to work under the car comfortably. The safest and preferred method would be to use a lift.
2. With the car jacked up, remove the 3 bolts from the driver-side headpipe flange at the catalytic converter and unbolt clamp on passenger side. Save these bolts for reuse in Step 7 (On 1996 models only, unclip oxygen O2 sensor connection and leave sensor in exhaust headpipe). Spray WD-40 on passenger side clamp to make removal of nuts easier.
3. With 15mm socket and 9" extension, loosen the rear muffler hanger bolts from mufflers, but leave the hanger in the rubber mount.
4. Place a floor jack (or other support) under the center muffler (see "X" on diagram). Raise jack (or other support) until the weight of the system is off the spring hangers. With a 13mm socket, unbolt and remove the 4 hanger bolts. Remove rear muffler hangers from the rubber mount.
5. With the system spring hanger bolts removed, lower the system just a few inches. Using a no-mar hammer, tap exhaust back where it is still attached at the catalytic converter. It may help if you have assistance to pull the system back while you tap on it. Remove muffler hangers from the rubber mount.
6. With the previous system now removed, you are ready to install your new CORSA exhaust system. To ensure proper seating, sandpaper the driver side catalytic converter flange. Also, sand the outer portion of the passenger side catalytic converter slip-over tube (On 1996 models, use a 7/8" wrench to remove oxygen O2 sensor and re-install O2 sensor in CORSA headpipe).
7. Install CORSA headpipes (A & B) onto catalytic converters. Install supplied bolts (5/15"- 18 x 5/8") on existing spring hanger (H) just as original system was installed. Use existing driver-side flange bolts and tighten lightly. Install supplied 2 3/4" Easy Seal clamp on passenger side headpipe. **DO NOT TIGHTEN** (On 1996 model, screw in oxygen O2 sensor).
8. **INSTALLATION NOTE:** Be sure to apply the anti-seize lubricant that has been provided to all bolts, fasteners, and clamps. A pouch with anti-seize lubricant is included with the hardware kit. Apply the supplied anti-seize lubricant to the threads **ONLY** of all TORCA band clamps. Failure to follow this procedure can cause the nuts to seize on clamps and potentially damage threads. **WARNING:** Be sure to thoroughly clean hands after use. Anti-seize lubricant will tarnish stainless steel parts.
9. With floor jack (or other support), raise center muffler (C) making sure TORCA band clamps are first placed on each side of center muffler (C).
10. Slip center muffler (C) in place, making sure the driver's side pipe is inserted fully into headpipe (A). Position the center muffler equal distances using each side of the "tunnel" as a guide. Lightly tighten the driver's side headpipe TORCA band clamp (1). Push passenger side headpipe (B) into center muffler until fully seated. After positioning the center muffler TORCA band clamp (2) over the slotted area of the headpipe, lightly tighten. Install Easy Seal clamp (7). Position with bolts down.
11. Attach the other end of the center muffler to existing spring hanger (I) and supplied 1/2" bolts and nuts. Lightly tighten. **NOTE: On 1990 ZR-1 Corvettes, the CORSA supplied Easy Seal clamp (7) replaces the factory flange connection on the passenger side headpipe.**
12. Before installing the under-the-axle pipes (D & E) to center muffler, make sure the TORCA band clamps (3 & 4) are slipped on the under-the-axle pipes first. Then install the under-the-axle pipes. **DO NOT TIGHTEN.**
13. Install the new CORSA rear mufflers (F & G) and slide each muffler hanger into rubber mount.



NOTE: IMPORTANT - Make sure that the small drain or weep hole in muffler faces down when muffler is installed.



(continue)

14. Attach under-the-axle pipes to rear mufflers and again lightly tighten TORCA band clamps (5 & 6) over slotted area of pipes.
15. With everything installed, you should now be able to move the system around to make final adjustments. Adjust and align exhaust tips and tighten remaining TORCA band clamps. **Tighten all Torca clamps to 45 ft.-lb.**
16. Lower the car, check for leaks and enjoy your new CORSA exhaust system.
17. It is **STRONGLY SUGGESTED** that all clamps be checked and tightened (if necessary) after road testing the vehicle and after system has cooled.

NOTE: During cold weather start-ups, you may experience an exhaust sound that is deeper and louder in tone than usual. This is temporary and will diminish to normal once your engine has reached its normal operating temperature.

NOTE: Immediately following the installation of your exhaust system, you may experience a trace of smoke after initial start-up. DO NOT be alarmed. The smoke is caused by the burning of a small amount of forming oil residue used in the manufacturing process.

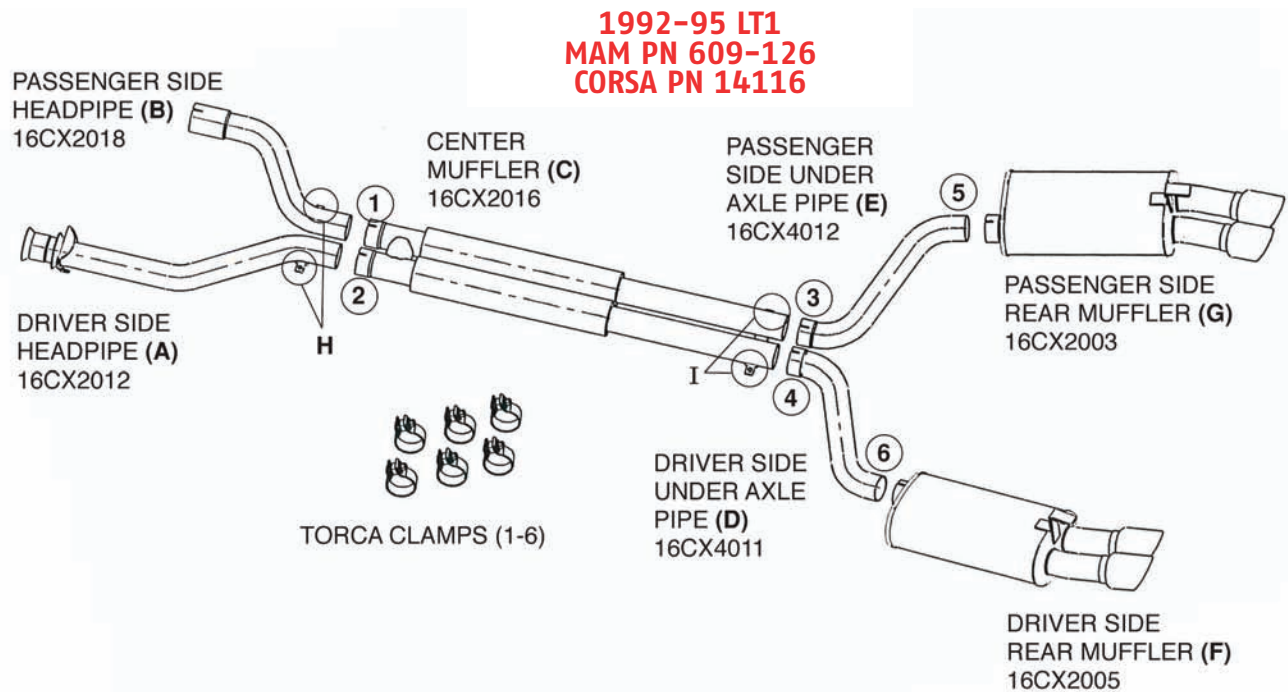

NOTE: During cold weather start-ups, you may experience an exhaust sound that is deeper and louder in tone than usual. This is temporary and will diminish to normal once your engine has reached its normal operating temperature.

NOTE: Immediately following the installation of your exhaust system, you may experience a trace of smoke after initial start-up. DO NOT be alarmed. The smoke is caused by the burning of a small amount of forming oil residue used in the manufacturing process.

**1990-95 ZR1 (LT5)
MAM PN 609-128
CORSA PN 14117**

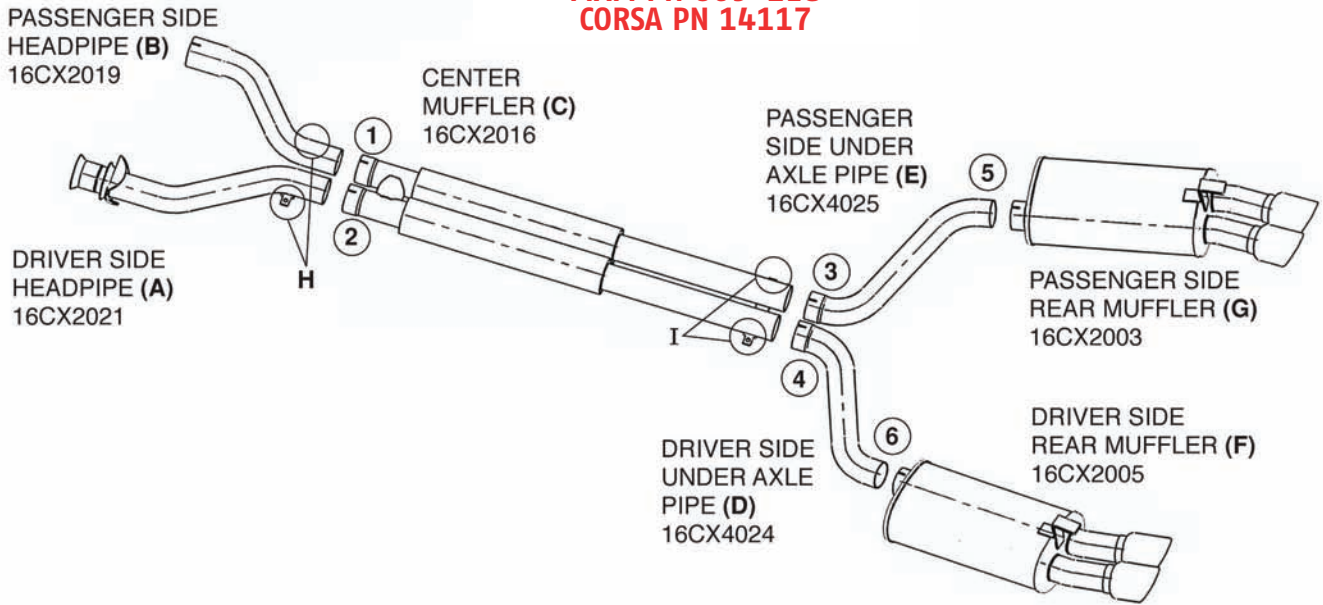

**1996 LT1/LT4
MAM PN 609-130
CORSA PN 14118**

