



Part Number

323-244
340-041

Application: 323-244 fits 1976-1977 Standard Beetle, 1956-1974 Ghia,
1969-1978 Thing & various off road models.
340-041 fits 1971-1979 Super Beetle

Tow Bar for Air-Cooled VW

Part Includes

- 1 - Tow Bar
- 1 - Mounting Plate
- 2 - Pins
- 2 - Spring Clips



Tools Needed

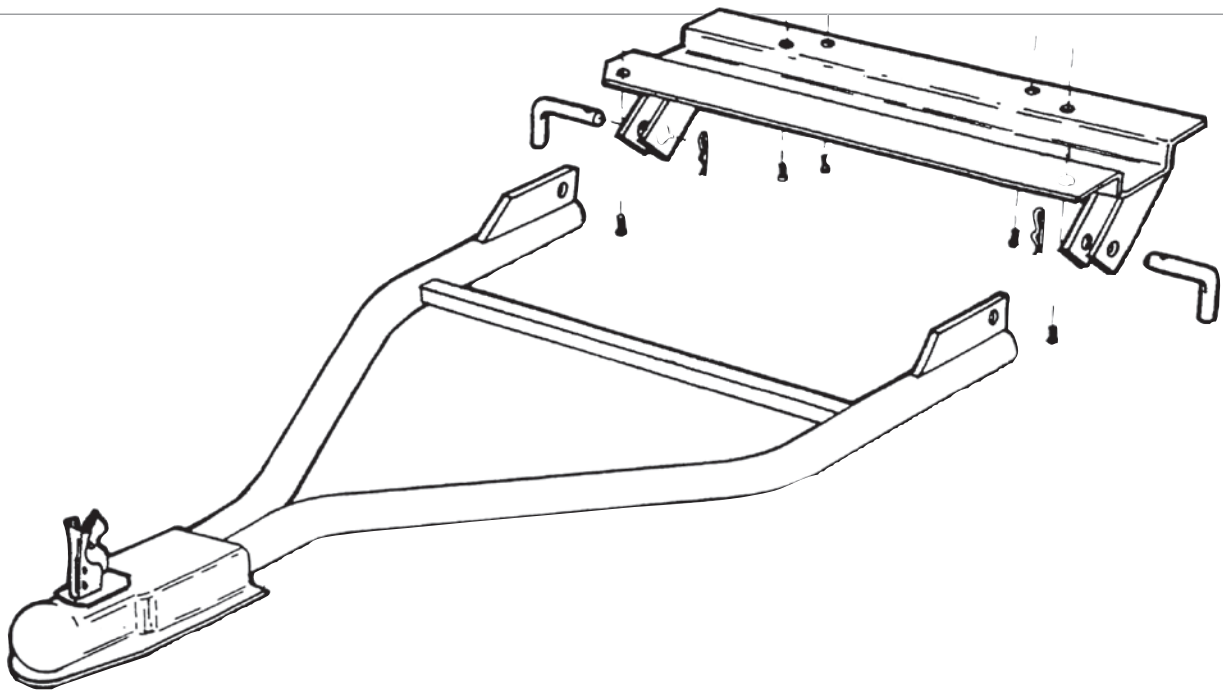

STEP 1.

Once fitted, the mounting plate can become a permanent fixture on the car and need not be removed when the car is in regular use.

STEP 2.

The mounting plate fits on the front underside of the car with the channel facing up and covering the sway bar. The protruding brackets for the tow bar attachment face forwards.

STEP 3.

The holes on the flanges of the mounting plate line up with existing bolts on the underside of the car. All cars have two existing bolts in the front of the sway bar. Behind the sway bar there are usually four bolts, but sometimes only two will be found. (See diagram A)

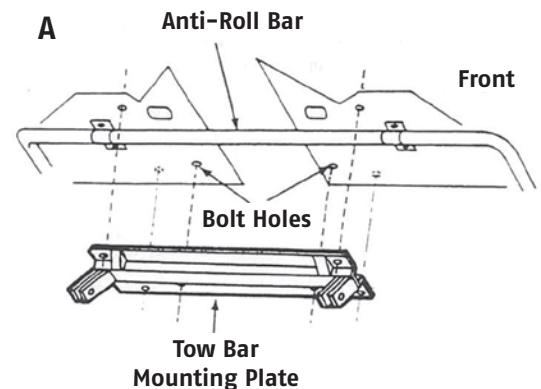

MAMotorworks



Midamotorworks



blog.autotainment.com

17082 N. US Hwy 45, P.O. Box 1368, Effingham, IL 62401
800.500.1500 • Worldwide: 217.540.4200 • FAX: 217.540.4800
www.mamotorworks.com • mail@mamotorworks.com

©Mid America Motorworks, Inc. All rights reserved.



323-244
340-041

Tow Bar for Air-Cooled VW (cont.)

STEP 4.

Remove the bolts on the car and position the mounting plate on the car. Carefully check that the bolt holes line up with the holes in the mounting plate. If the alignment of the holes is significantly off, (which is unusual) file the appropriate holes in the base plate until good alignment is obtained.

STEP 5.

At this stage it may be necessary to obtain some longer 8mm bolts. The old bolts may not be long enough due to the extra thickness of the mounting plate flange that they now have to pass through. Attach the mounting plate to the car. For extra strength and security we recommend the use of Loctite or similar product on the bolts.

STEP 6.

The tow bar can now be fitted to the mounting plate by placing the single tab at the end of each tow bar tube between the two protruding tabs on the mounting plate and inserting the retaining pins. (See diagram B)

STEP 7.

Snap the spring clips through the small holes in the end of the pins. It is vital to make sure that the clips are fully on the pins. They must be right up to the larger hole in the clip. (See diagram C)

STEP 8.

Adjust the coupler to correctly fit the ball as shown in diagram D.

ADJUSTING THE COUPLER

- A. Place the coupler over the ball and lock it in position by pushing down on the locking lever.
- B. Adjust the coupler by rotating the lock nut until a good firm contact is made between the ball and the coupler.

STEP 9.

If a pin or clip are lost always buy another identical set. Do not substitute with inferior material as this may fail in use and cause an accident.

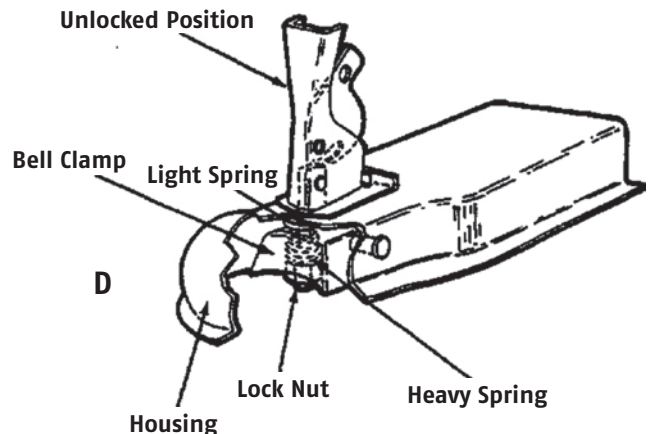
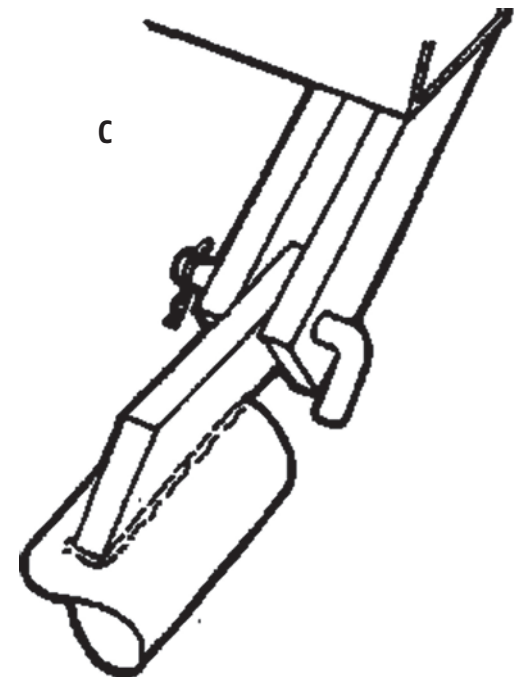
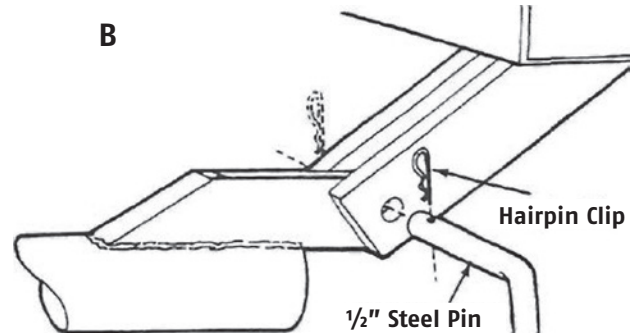



323-244
340-041

Tow Bar for Air-Cooled VW (cont.)

STEP 10.

Install safety chains with identical or greater load rating as the tow bar.
(See diagram E and suggestions.)

SAFETY CHAIN FITTING

- A. We suggest fitting the safety chains under the tow bar in the cross over pattern shown here.
- B. Make sure the chain is firmly connected to the frame of both vehicles.

STEP 11.

For additional security it is worth putting a small nut and bolt or padlock through the hole in the latch release lever. This will prevent the coupler accidentally being opened and also discourage tampering.

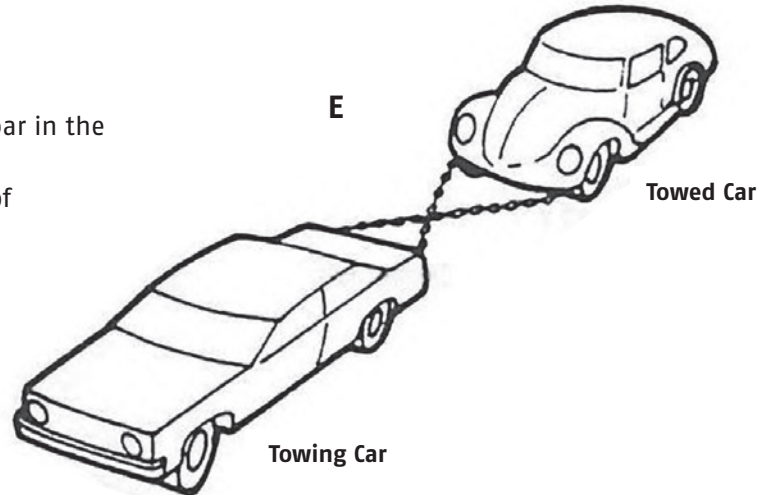

GENERAL SAFETY RECOMMENDATIONS

1. This tow bar is to be used on manual transmission models only. It cannot be used on Automatic Stick Shift Models.
2. Make sure the front wheel alignment on the car being towed is correct.
3. Disconnect the battery and, with the ignition key, unlock the steering column lock to allow the front wheels to follow the towing vehicle when cornering. The steering wheel must be allowed to rotate freely from lock to lock.
4. The tow bar must be parallel with the ground when it is attached to both vehicles. If it is angled there is the possibility of damage or an accident while towing. If it is found that an angle exists, the height of the tow bar on the towing vehicle will have to be changed.
5. Always use safety chains.
6. Make frequent checks of the installation when in use. Carefully examine all pins and the coupler adjusting bolt to make sure they are correctly fitted and in good condition. In addition check all welds for signs of cracks or distortion.
7. Do not use the towed car as a trailer for storing suitcases etc. as you may well exceed the towing capacity of the tow bar.
8. Do not back up when towing or damage to the towed vehicle's steering and suspension may result.