

Note: We provide 6 ABS filler pad shims to fill any gap or looseness that may remain in the front spring retainer (Item #4).

1984-87 Style Front Spring Mounting Diagram

- |                                   |                                 |
|-----------------------------------|---------------------------------|
| 1. Spring Protector to Frame Bolt | 6. Front Spring Cushion         |
| 2. Spring Protector               | 7. Front Spring Cushion Bearing |
| 3. Spring Pad                     | 8. Front Spring Cushion Seat    |
| 4. Front Spring Retainer          | 9. Front Spring Retainer Shim   |
| 5. Front Transverse Spring        | 10. Front Spring Retainer Nut   |

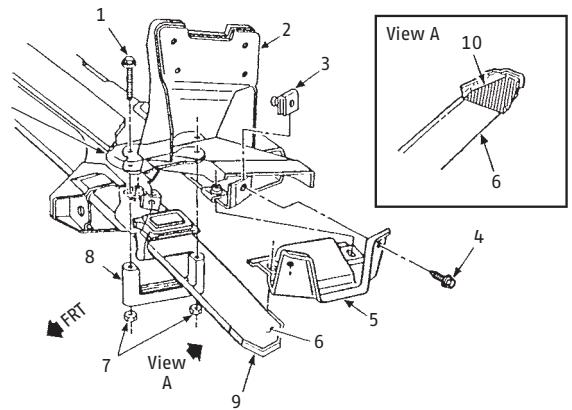

1988-96 Style Front Spring Mounting Diagram

- |                                   |                            |
|-----------------------------------|----------------------------|
| 1. Spring Retaining Bolt          | 6. Front Transverse Spring |
| 2. Drive Train & Susp. Frame      | 7. Spring Retainer Nut     |
| 3. Multi-Thread "U" Nut           | 8. Front Spring Retainer   |
| 4. Spring Protector to Frame Bolt | 9. Spring Pad              |
| 5. Spring Protector               | 10. Apply Rubber Lubricant |

## 1984-1996 Corvette Lower your Corvette for Better Handling

Are you looking for quicker response and improved handling from your 1984-96 Corvette? Well, look no further. Lowering your Corvette will give you the advantage of a lower center of gravity which offers better road handling and cornering ability as well as a more aggressive stance.

Lowering any 1984-96 Corvette can be accomplished with the addition of a **Suspension Lowering Kit**. Mid America Motorworks offers an inexpensive kit that allows any C4 owner to lower the ride height of their Corvette approximately 1 inch. The lower center of gravity is very beneficial in reducing body roll and increasing cornering capability.

The **Suspension Lowering Kit** consists of a pair of extended length rear spring mounting bolts, two locking nuts, and a pair of thinner-than-stock Urethane wedges to replace the stock rubber front spring mounting cushions.

By replacing the stock rear spring bolts with longer bolts the rear suspension height can be lowered accordingly. The longer bolts have 4 inches of thread for adjustment that allows fine tuning of the rear suspension height.

Most 1984-87 Corvettes have

stamped steel retainers that clamp the rubber front mounting cushions and the spring in place against the frame member. The 1988-96 Corvettes utilize cast aluminum retainers to clamp the cushions and spring in place. Replacing the rubber front spring cushions with thinner, urethane wedges repositions the front spring closer to the frame which effectively lowers the front suspension height.

On most 1984-87 Corvettes, the stamped steel retainers must be replaced with the later model 1988-96 aluminum retainers. On all models the retainers should be trimmed down to allow the thinner wedges to be clamped securely with the spring to the frame.

Mid America Designs has formulated a kit which provides the upgraded 1988-96 aluminum retainers and mounting hardware necessary to install the lowering kit on 1984-87 Corvettes. The **Spring Mounting Upgrade Kit** should be ordered when installing the **Suspension Lowering Kit** on any 1984-87 Corvette that has stamped steel front spring mounting retainers.

We highly recommend referring to a **GM Service Manual** for the procedure to

remove and re-install the front spring, as it is compressed under extreme force and could cause serious injury if not properly handled. After the lowering kit is installed the car should be driven a short distance and re-aligned. **MAM**



602-712

Our **C4 Corvette Lowering Kit** includes everything necessary to lower you 1988-1996 Corvette. The Kit includes Urethane Front Suspension Wedges and Extended Rear Spring Bolts with adjustable Nyloc Nuts that allow you to lower the ride height of your Corvette approximately 1 inch without changing ride quality. The lower center of gravity will reduce body roll and increase your Corvette's responsiveness to driver input.

**Tech Note:** 1984-1987 require the replacement of the OE stamped-steel Front Spring Outer Retainers with our Front Spring Outer Retainer Upgrade Kit, item # 602-714.

